

# Panasonic

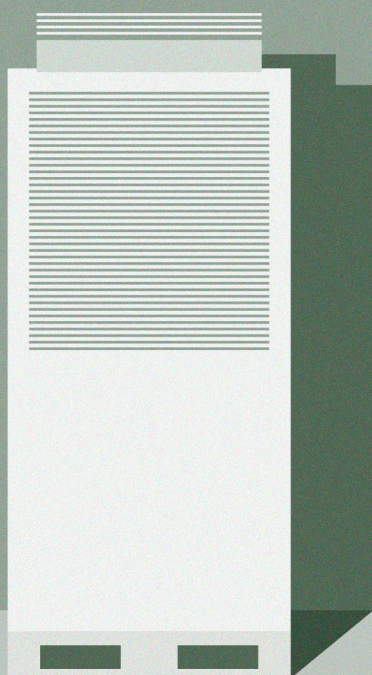

CONDENSING UNITS WITH  
NATURAL REFRIGERANT  
2024 / 2025



*PACi*

heating & cooling solutions



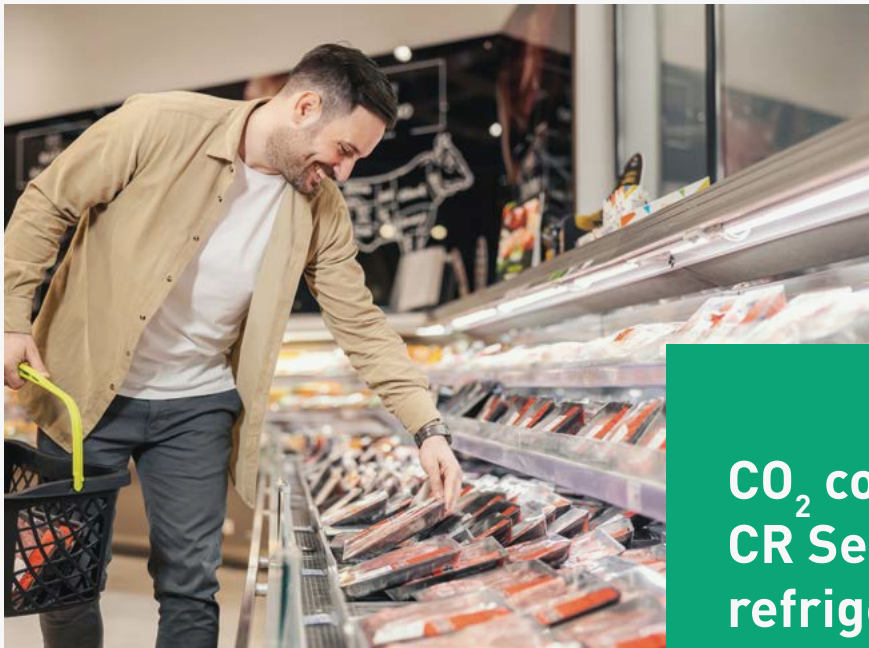

## CO<sub>2</sub> condensing units - CR Series with natural refrigerant

Panasonic's CO<sub>2</sub> condensing units - CR Series provide the ideal solution for supermarkets, convenience stores and gas stations. Keeping food always fresh at right temperature in showcases or cold rooms is a very critical point. And one of the biggest challenges for those retailers has been the expensive effects of refrigeration breakdowns which can result in costly product wastage.





### Choose the sustainable green solution by Panasonic → 548

Natural solution with high energy saving	→ 550
A sustainable refrigeration systems in your food retail	→ 552
The safe refrigeration systems for your healthcare business	→ 553
CO <sub>2</sub> transcritical condensing units - CR Series	→ 554
Technology by Panasonic	→ 556
Control and connectivity	→ 558
Range of CO <sub>2</sub> condensing units - CR Series	→ 560
CO <sub>2</sub> Condensing units - CR Series	→ 562

### Panasonic PACi NX Elite can cool rooms down to 8 °C → 564

Bringing nature's balance indoors	→ 566
PACi NX Series Elite wall-mounted · R32	→ 568
PACi NX Series Elite 4 way 90x90 cassette · R32	→ 569
PACi NX Series Elite ceiling · R32	→ 570
PACi NX Series Elite adaptive ducted unit · R32	→ 571



# Choose the sustainable green solution by Panasonic

Environmentally friendly CO<sub>2</sub> condensing units - CR Series and medium temperature solutions with PACi NX R32.



CO <sub>2</sub> condensing units - CR Series						Medium temperature solutions with PACi NX
MT/LT Type	MT Type	MT/LT Type	MT Type	MT/LT Type	NEW MT/LT Type	
<b>Capacity range (kW)</b>						<b>Capacity range (kW)</b>
4 (MT) / 2 (LT)	7,5	8 (MT) / 4 (LT)	15	16 (MT) / 8 (LT)	29 (MT) / 15 (LT)	2,1 to 23,2
<b>Low temperature</b>						<b>Low temperature</b>
✓	—	✓	—	✓	✓	—
<b>Medium temperature</b>						<b>Medium temperature</b>
✓	✓	✓	✓	✓	✓	✓
<b>High Temperature</b>						<b>High Temperature</b>
—	—	—	—	—	—	✓
<b>Heat recovery port</b>						<b>Heat recovery port</b>
—	✓	✓	—	✓	✓	—
<b>ET (evaporation temperature) set points range</b>						<b>Room temp. set point</b>
-45 ~ -5 °C	-20 ~ -5 °C	-45 ~ -5 °C	-20 ~ -5 °C	-45 ~ -5 °C	-45 ~ -5 °C	+8 ~ +24 °C WB
<b>Room size example (m<sup>2</sup>)*</b>						<b>Room size example (m<sup>2</sup>)*</b>
40 (MT) / 10 (LT)	80	80 (MT) / 20 (LT)	200	200 (MT) / 50 (LT)	300 (MT) / 75 (LT)	From 6

\* Room size is reference. Please contact to authorized Panasonic dealer for calculation.



Energy saving



Natural CO<sub>2</sub> / R744.

R744 refrigerant provides higher energy saving and lower CO<sub>2</sub> emission compared to R404A. Zero ODP and GWP=1 means natural substance.



Refrigerant R32.

Our heat pumps containing R32 refrigerant show a drastic reduction in the value of Global Warming Potential (GWP). An important step to reduce greenhouse gases. R32 is also a component refrigerant, making it easy to recycle.



Inverter Plus system.

Inverter Plus system classification highlights Panasonic's highest performing systems.



High efficiency compressor.

Powerful 2-stage CO<sub>2</sub> rotary compressor by Panasonic. It delivers high performance all year around.

High performance and indoor air quality



Super quiet.

Systems operate extremely quiet. Minimum 33 dB(A) @10 m with OCU-CR400VF8(SL).



Operating range up to 43 °C.

The system operates up to 43 °C, allowing for installation in various locations.



Anti corrosion coating.

Selectable fin type with or without an anti corrosion coating. The anti corrosion coating prevents salt damage for a longer lifespan.



Heat recovery port.

The heat recovery port is available to cut running costs as optional. By utilizing exhausted heat generated by refrigeration to the energy source for heating.



Automatic fan operation.

Microprocessor control automatically adjusts the outdoor fan speed in CO<sub>2</sub> systems for efficient operation.



5 Years compressor warranty.

We guarantee the outdoor unit compressors in the entire range for five years.

High connectivity



BMS connectivity.

The system can be supervised with major monitoring system.

Why CO<sub>2</sub>? Natural refrigerant.

EU F-Gas regulation is a key priority for European countries. It ensures compliance with the Kigali Amendment supporting international climate commitments on greenhouse gases and leading the global transition to climate-friendly HFC-free technologies. Carbon dioxide (R744) is regaining its place in the refrigeration world. Driven by environmental concerns, legislation now requires increased adoption of 'alternative' refrigerants, such as CO<sub>2</sub>. CO<sub>2</sub> is an environmentally-friendly solution, with zero ODP and "GWP" (Global Warming Potential)=1 means natural substance in the atmosphere.

In Europe a step-by-step HFC reduction has been in place since the F-Gas regulation was introduced in 2015. Countries all over the world have actively been preparing to enact the necessary domestic legislation to implement the agreement to reduce the use of HFCs. Panasonic is now able to provide a solution in Europe with CO<sub>2</sub> refrigeration systems to prevent global warming and to support environment-friendly retail operations. The following table shows how well R744 (CO<sub>2</sub>) performs regarding environmental impact and safety.

ODP (Ozone Depletion Potential) = 0 - GWP (Global Warming Potential) = 1

	Next generation refrigerant			Current refrigerant	
	CO <sub>2</sub>	Ammonia	Isobutane	R410A	R404A
ODP	0	0	0	0	0
GWP	1	0	4	2090	3920
Flammability	Non flammable	Light flammable	Flammable	Non flammable	Non flammable
Toxicity	No	Yes	No	No	No

Comparison of CO<sub>2</sub> emissions

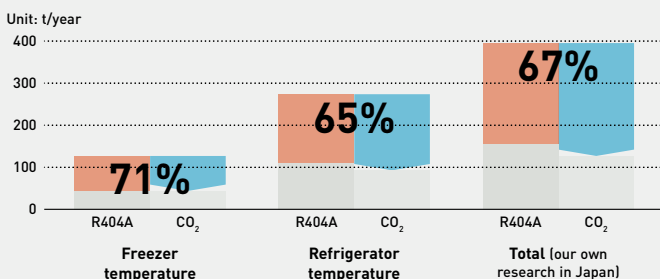

Energy saving  
25,4% freezer  
16,2% refrigeration

CO<sub>2</sub> emission  
67% reduction

Direct influence <sup>1)</sup> Indirect influence <sup>2)</sup>

1) Direct influence presents the effect of refrigerant leakage comparing R744 (CO<sub>2</sub>) with R404A.  
2) Indirect influence presents CO<sub>2</sub> emissions linked to power consumption of CO<sub>2</sub> unit and conventional units.  
By Panasonic research in Japan. Comparing 6 shops average for R404A Inverter multi condensing unit.



## Natural solution with high energy saving

Panasonic's range of CO<sub>2</sub> condensing units - CR Series with natural refrigerant, and R32 complete systems for HT applications offer a reliable solution for a wide range of applications, including convenience stores, supermarket, gas stations and cold rooms.





Showcases.

Convenience stores, supermarkets, gas-stations.

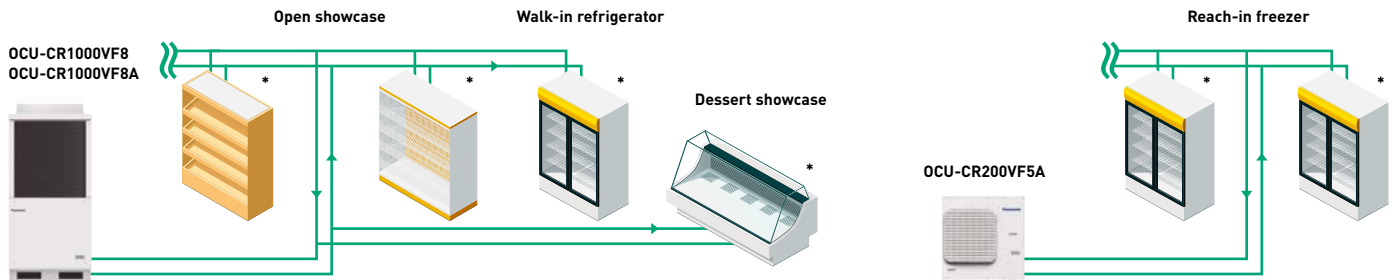

\* Controllers: PAW-CO2-PANEL-C or local supply.

Cold room application to keep food fresh

Multiple installation capabilities. Unparalleled flexibility:

- Food retail applications (convenience store, supermarkets, gas-stations)
- Food service applications (restaurants, canteens, schools)
- Non-food applications (warehousing, industrial storage, healthcare)

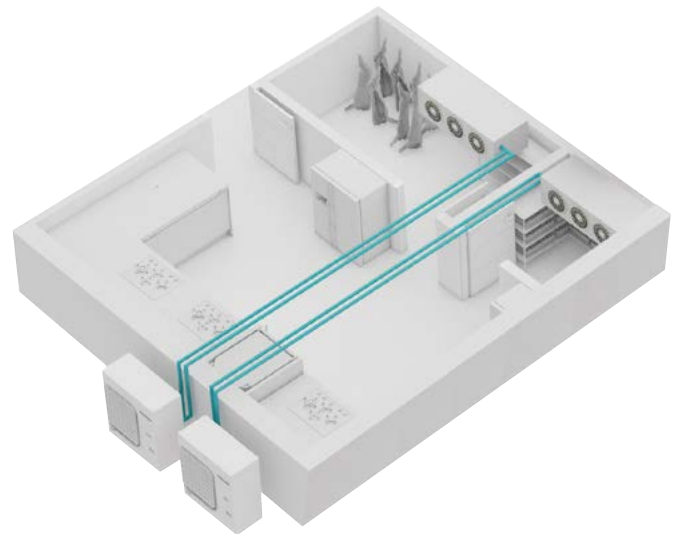
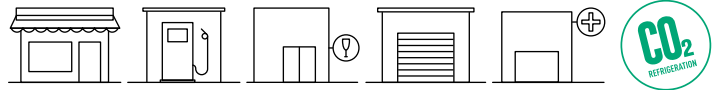

Cold room application integrated with PACi NX Series

Panasonic offers various solutions for cold rooms by combining a wide range of products. Integrated with PACi NX Series, it allows for flexible design and installation.



CO<sub>2</sub> condensing units - CR Series for refrigerated room.



PACi NX Series for cooling rooms between 8 °C WB and 24 °C WB.

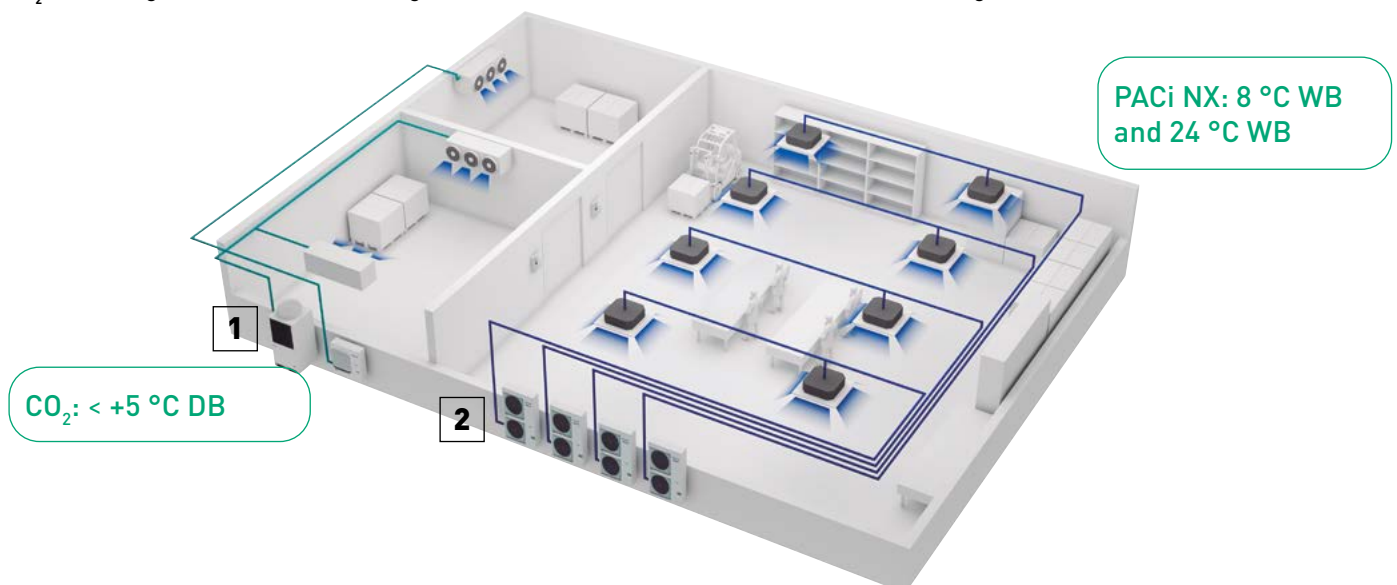



# A sustainable refrigeration systems in your food retail

CO<sub>2</sub> refrigerant is the choice to curb carbon footprint of any business organization, especially to food retailers, to whom it brings key advantages.

Panasonic professional strongly supports your projects to meet customer's request!

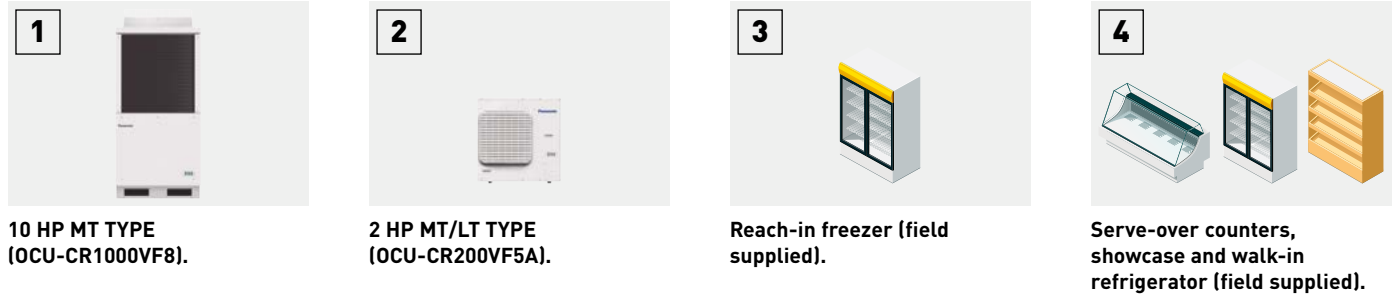

1  
10 HP MT TYPE  
(OCU-CR1000VF8).

2  
2 HP MT/LT TYPE  
(OCU-CR200VF5A).

3  
Reach-in freezer (field  
supplied).

4  
Serve-over counters,  
showcase and walk-in  
refrigerator (field  
supplied).

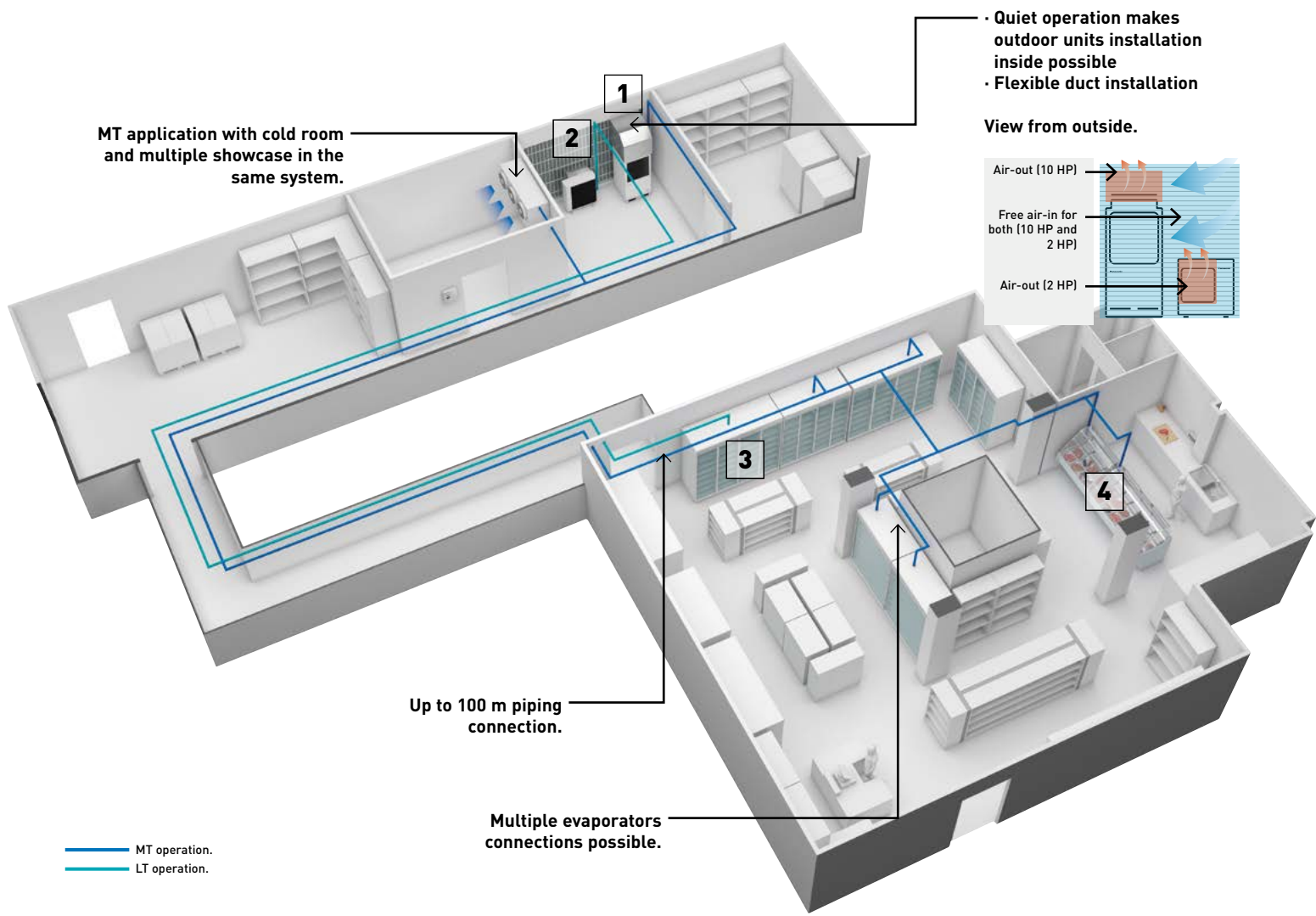

- Quiet operation makes outdoor units installation inside possible
- Flexible duct installation

**View from outside.**

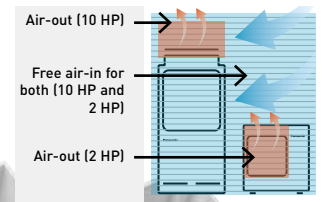

— MT operation.  
— LT operation.

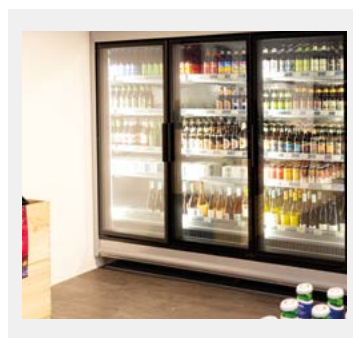

**Nolan's Supermarket.**

Nolan's Supermarket celebrated its 60th year in business with an extension and full refurbishment which completely overhauled the existing store. A particular focus of the project was to create a state-of-the-art refrigeration system operating on the 'Zero Ozone Depletion' plus ultralow GWP of 1 natural refrigerant CO<sub>2</sub> and as part of the scheme. Panasonic CO<sub>2</sub> condensing units - CR Series have been chosen because of the high performance and reliable quality.



# The safe refrigeration systems for your healthcare business

CO<sub>2</sub> is the right refrigerant to curb carbon footprint of any business organization. In addition, there are advantages specially for healthcare business. The project example shows one of the warehouse in the healthcare laboratory which requires several cold rooms there to keep bio-products safely.



1  
10 HP LT TYPE  
(OCU-CR1000VF8A).



2  
10 HP MT TYPE  
(OCU-CR1000VF8).

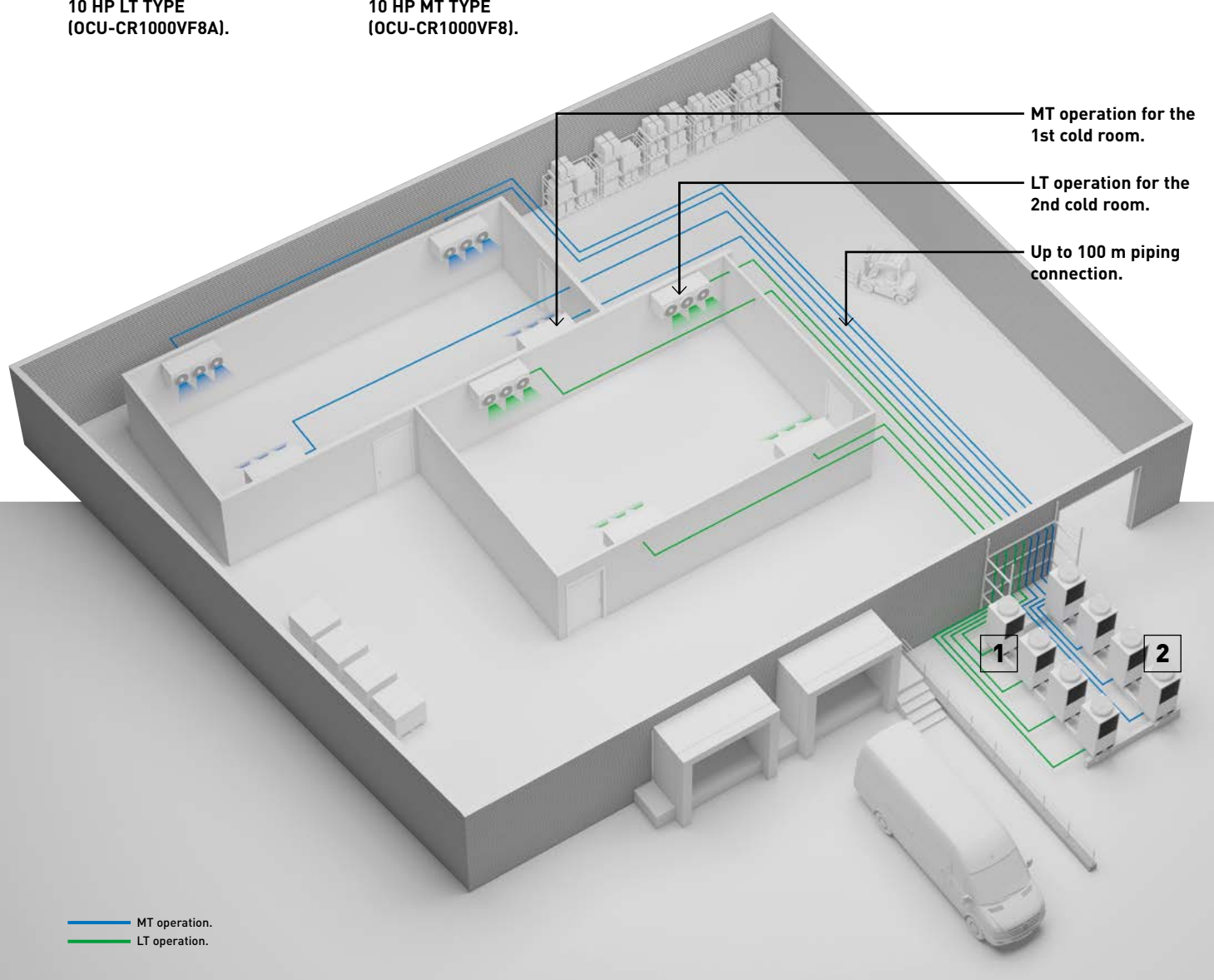

## STEMCELL Technologies.

STEMCELL Technologies is a global biotechnology company that develops, manufactures and sells products and provides services that support academic and industrial scientists.

Panasonic CO<sub>2</sub> condensing units - CR Series have been chosen to fulfill the expectation of environmental-friendly and safety requirements.

The products with reliable quality and high performance was also an essential point.



# CO<sub>2</sub> transcritical condensing units - CR Series

CR Series offer a wide range of refrigeration systems, meeting the specific needs of small retail stores.



## New CR Series 20 HP MT/LT model.

The CR Series now includes 20 HP MT/LT model, a highly efficient multi compressor solution.

- Multi-compressor systems
- Smaller footprint
- Maximum piping length of 100 m
- Cooling capacity can be controlled from 25 to 100% under partial load
- Flexible and precise control capabilities with digital input/output

### Energy efficient multi compressors operation.

By distributing the workload between two compressors, the system operate efficiently, adjusting capacity to match the varying cooling demands. Compressors 1 and 2 alternate every 10 days to ensure even load distribution.

Example of compressor operation.

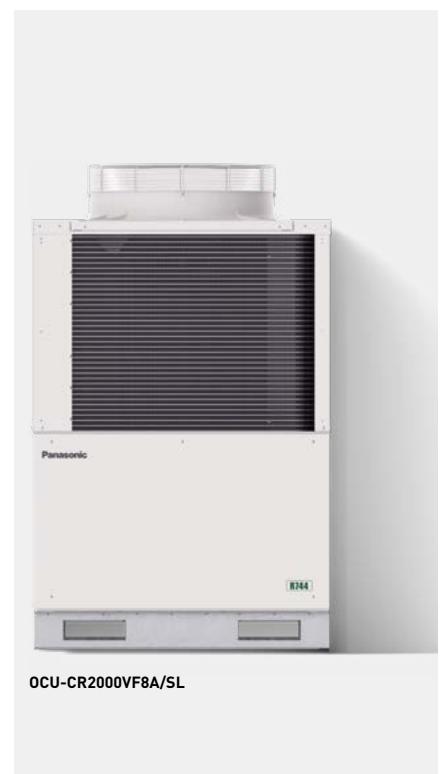
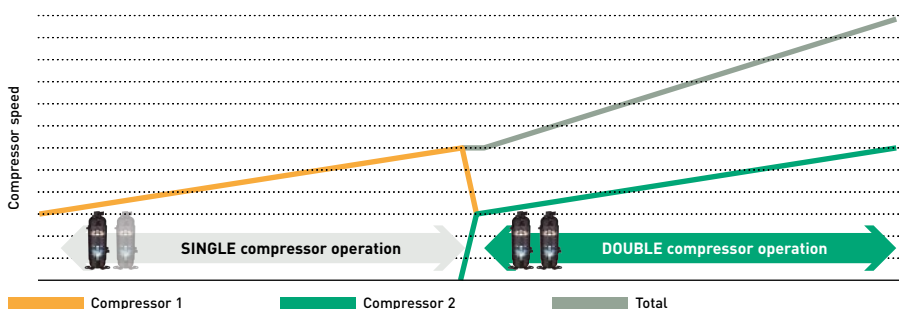



## Superior cooling capacity at each evaporating temperature.

CO<sub>2</sub> transcritical condensing units - CR Series have a high cooling capacity at each set point. The CO<sub>2</sub> 2-stage compressor developed by Panasonic is designed to compress CO<sub>2</sub> refrigerant twice; it reduces the load in operation by half (compared to 1-stage refrigerant compression) and delivers increased durability and reliability.

Units can be programmed to run at low and medium temperatures at initial set-up. These settings can then be modified by turning a simple and user friendly rotary switch to further enhance energy savings.

### MT/LT Type: 200VF5A - 4 / 2 kW.

3,83 SEPR cooling.  
1,92 SEPR freezing.

\* SEPR values has been tested at 3-part laboratory.



OCU-CR200VF5A(SL) <sup>1)</sup>.  
Cooling capacity (kW)

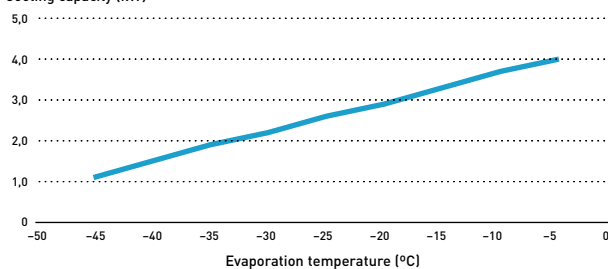

### MT Type: 400VF8 - 7,5 kW. MT/LT Type: 400VF8A - 8 / 4 kW.

2,45 SEPR cooling.  
1,56 SEPR freezing.

\* Model 400VF8A.

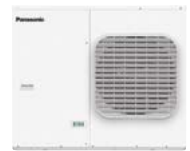

OCU-CR400VF8(SL) / OCU-CR400VF8A(SL) <sup>2)</sup>.  
Cooling capacity (kW)

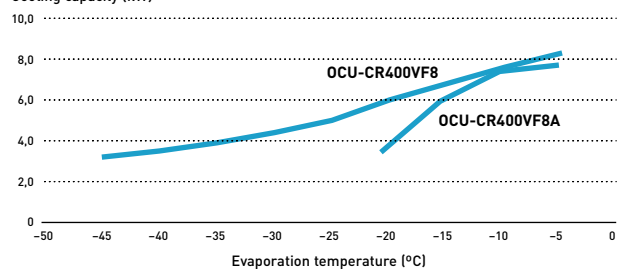

### MT Type: 1000VF8 - 15 kW. MT/LT Type: 1000VF8A - 16 / 8 kW.

2,86 SEPR cooling.  
1,49 SEPR freezing.

\* Model 1000VF8A.



OCU-CR1000VF8(SL) / OCU-CR1000VF8A(SL) <sup>2)</sup>.  
Cooling capacity (kW)

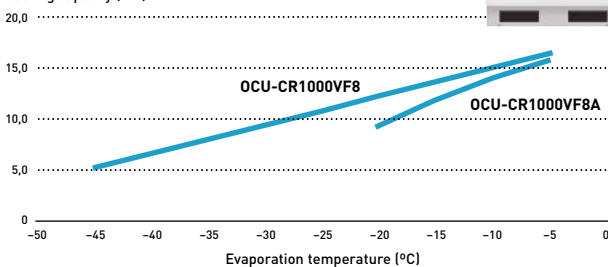

### NEW MT/LT Type: 2000VF8A - 29 / 15 kW.

3,10 SEPR cooling.  
1,64 SEPR freezing.

OCU-CR2000VF8A(SL) <sup>1)</sup>.  
Cooling capacity (kW)

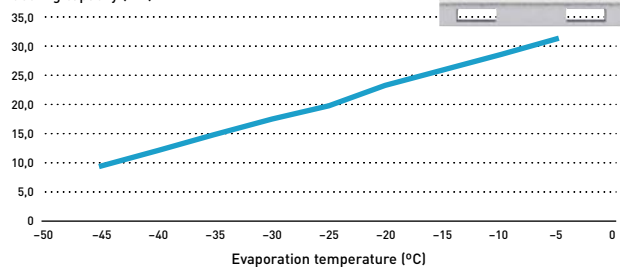

1) Ambient temperature: 32 °C, 230 V, refrigerant: R744, suction gas temperature: 18 °C. 2) Ambient temperature: 32 °C, 400 V, refrigerant: R744, suction gas temperature: 18 °C.

## 1 Superior efficiency with reliable quality

- Panasonic has combined the 2-stage compressor with the split cycle for increased efficiency
- High seasonal performance. SEPR: Maximum 3,83 in cooling, 1,92 in freezing <sup>1)</sup>
- High COP at high ambient temperature

1) 200VF5A.

## 2 Heat recovery port <sup>1)</sup> as renewable energy

- Maximum 16,7 kW <sup>2)</sup> of heating for free
- Optional possibility to get subsidy (depending on location)
- Easy connection process

1) For models 1000VF8A and 2000VF8A. 2) For model 1000VF8A.

## 3 Flexible installation

- Set-points at medium or low temperature available depending on applications
- Compact unit
- Silent operation
- Long piping length: Maximum 100 m <sup>2)</sup>
- High external static pressure
- Transfer pressure control for stable electric expansion valve control in showcases <sup>2)</sup>

2) For models 1000VF8A and 2000VF8A.

## Technology by Panasonic

Excellent quality control established by skilled factory team.

Reliability is our main target and therefore we offer compressor warranties of 5 years, and 2 year warranties on other components!



### Reliable CO<sub>2</sub> technology by Panasonic

- Reliable quality: Made in Japan
- 19500 units sold and installed in more than 5200 retail operations such as convenience stores and supermarkets in Japan\*
- Excellent quality control established by skilled factory team
- Panasonic offers 5 year warranties on compressors and 2 years on components
- The 5 year compressor warranty matches the products long lifespan

\* As of the end of December 23.



## Panasonic's combined technology of the 2-stage compressor with the split cycle.

- Panasonic 2-stage rotary compressor delivering powerful performance for more than 20 years
- Split cycle\* enhances cooling effect

\* Available for 200VF5A, 400VF8A, 1000VF8A and 2000VF8A models.

\*\* In the case that the standard cycle with 1-stage rotary compressor was compared.

Watch the highlighted technology video.

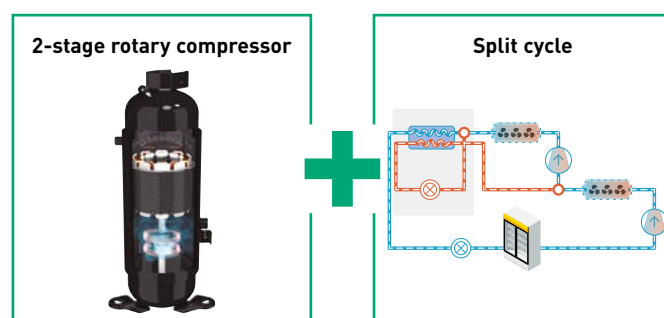

### Standard cycle.

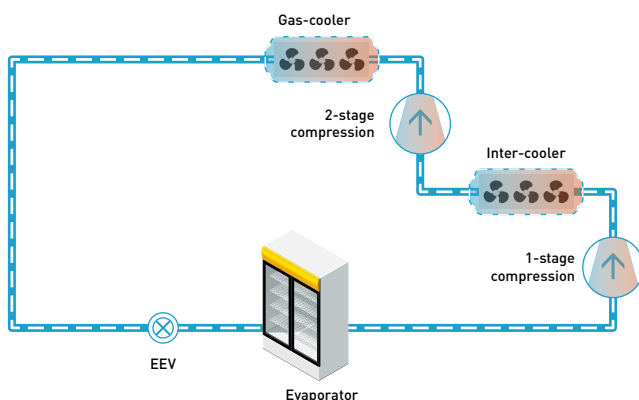

### Split cycle.

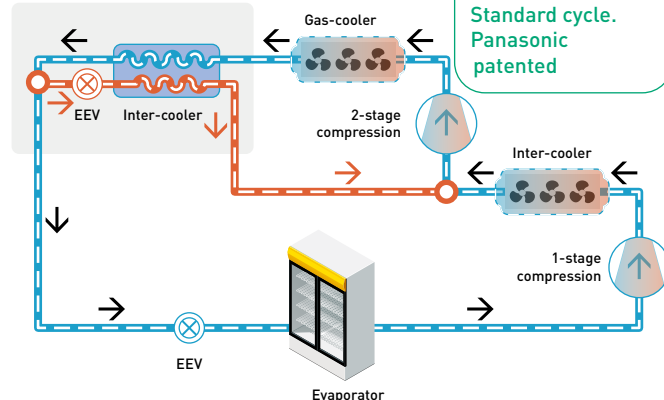

## Heat recovery function for heating

This function offers refrigeration combined with heating all in one system. The ground-breaking solution allows for increased opportunity to cut running costs by utilizing exhausted heat from refrigeration and transferring to the energy source for heating.

16,7 kW<sup>1)</sup>  
Of hot water  
for free

### What is heat recovery function?

#### Solution example.

Heat recovery system can produce both heating and refrigeration.

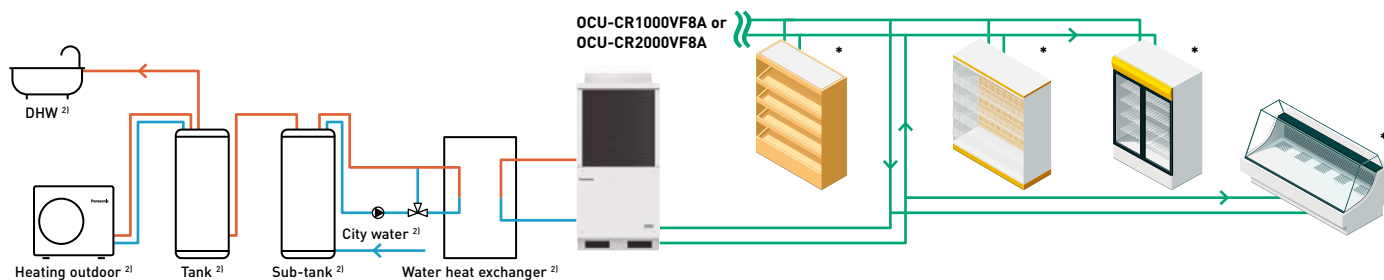

1) Tested with OCU-CR1000VF8A. Under the condition: ambient temperature 32 °C, evaporation temperature -10 °C. 100% Partial load. 2) Local supply.

\* Controllers: PAW-CO2-PANEL-C or local supply.

## Refrigeration designer available in Panasonic PRO Club.

This simple design tool supports engineers, installers, and technicians to make a quick calculation for commercial refrigeration systems.

- Evaporation temperature selection
- Cooling capacity calculator
- Refrigerant pipe calculation
- Electric expansion valves calculation
- Refrigerant amount calculation

Ready to works on all devices, computers, tablets and smartphones!!

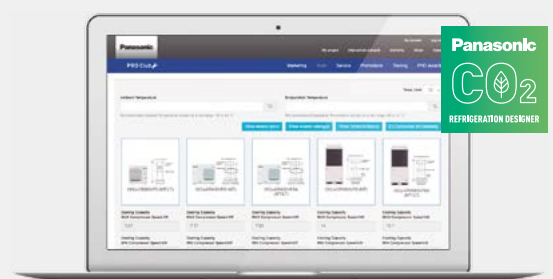

PRO Club

www.panasonicproclub.com or  
connect simply with your smartphone  
to the PRO Club using this QR



## Control and connectivity

Panasonic CO<sub>2</sub> condensing units - CR Series is optimized with Panel-C intelligent controller and a service checker for professionals. It can be easily integrated with major monitoring systems.



### Modbus compatibility with monitoring system

Panasonic CO<sub>2</sub> condensing units - CR Series can be supervised by major monitoring system such as CAREL, Eliwell, Danfoss, RDM and Pego. Monitoring system ensures the recording, monitoring and reporting of temperature conditions etc... of entire CO<sub>2</sub> condensing units - CR Series system at shops.

#### Monitoring system



Standard boss & boss-mini



AK-SM Series\*



TelevisGo



DMTOUCH



TeleNET

\* M2M1-10 gateway (Model code: FDS021) is required in addition to the monitoring system. M2M1-10 gateway is a local supply.



## Control panel and electric expansion valves.

Panel-C, an intelligent controller with a compact chassis. This controller has the smart program especially for showcases and cold rooms. Electric expansion valves (EEVs) are ready with 7 different sizes to meet precisely the field demand and it's delivered with Panel-C as a kit.

### Intelligent controller with compact chassis. Panel-C.

- MPXPRO control fully pre-programmed for MT and LT on the same panel
- Compact structure size: 300 x 220 x 120 mm
- Necessary cables, EEV stator, temperature and pressure probes as standard equipment
- Ultracap technology as standard equipment for emergency EEV's closing in the event of mains power failure
- Smart defrost functions, advanced superheat control, light and showcase curtain management, etc
- Own display user terminal plus keypad for programming, built-in switching power supply, Modbus, etc
- Management of HACCP alarms

### Electric expansion valves (EEVs) line-up.

- EEV's E2V-CW with 3/8" ODF copper fittings for high pressure applications (CO<sub>2</sub>)
- Operation refrigerant temperature: -40 T 70 °C
- Maximum operating pressure for all the models 03, 05, 09, 11, 14, 18, 24 (MOP) 140 bar
- Maximum operating pressure difference for 03, 05, 09, 11, 14, 18, (MOPD) 120 bar and 24 (MOPD) 85 bar
- Bipolar stator hermetic IP69K as standard equipment (supplied on panel)
- Mechanical strainer as standard equipment (500 mm mesh)
- Equipercetile control particularly effective at partial load with reliable operation even after 1,2 billion steps

\* Please refer the model references in page 562.



## CO<sub>2</sub> service checker

### PAW-CO2-CHECKER

The service checker is a useful tool which supports your technical tasks on the field such as commissioning, maintenance and troubleshooting for Panasonic CO<sub>2</sub> condensing units - CR Series.

#### Main features:

- Reading and recording variable technical parameters
- Main technical parameters available\*: pressures, temperatures, opening of expansion valves, states of solenoid valves, rotational speeds of the gas-cooler fan motor, frequency and compressor's current, etc.
- Setting change of operating values possible
- 2D graph visualization for the detailed analysis
- Monitoring an alarm status, for example the status of the compressor oil level, etc.

\* Please check all the parameters available in the manual.

To use it, is necessary to download free Device Manager software from the Eliwell website:

Visit: <https://www.eliwell.com/en/Family/DeviceManager.html> using this QR.

Eliwell product name: Device Manager 100. Eliwell part number: DMP1000002000.



**eliwell**  
by Schneider Electric

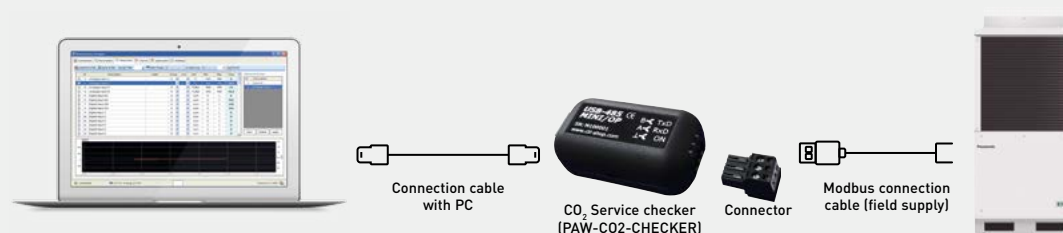

## Range of CO<sub>2</sub> condensing units - CR Series

Outdoor units	MT	4,0 kW	7,0 kW	8,0 kW	15,0 kW	16,0 kW	29,0 kW
	LT		2,0 kW		4,0 kW		8,0 kW

2 HP MT / LT  
(200VF5A)



OCU-CR200VF5A  
OCU-CR200VF5ASL

4 HP MT  
(400VF8)

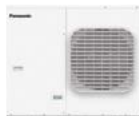

OCU-CR400VF8  
OCU-CR400VF8SL

4 HP MT / LT  
(400VF8A)



OCU-CR400VF8A  
OCU-CR400VF8ASL

10 HP MT  
(1000VF8)



OCU-CR1000VF8  
OCU-CR1000VF8SL

10 HP MT / LT  
(1000VF8A)



OCU-CR1000VF8A  
OCU-CR1000VF8ASL

**NEW** 20 HP MT /  
LT (2000VF8A)



OCU-CR2000VF8A  
OCU-CR2000VF8ASL



# Accessories and control

## Control panel and electric expansion valves





### Control panel (Panel-C) with electric expansion valves (EEV) included.

Panel-C includes MPXPRO control, stator, probes, etc.

EEV size E2V03CWAC0.	EEV size E2V05CWAC0.	EEV size E2V09CWAC0.	EEV size E2V11CWAC0.	EEV size E2V14CWAC0.	EEV size E2V18CWAC0.	EEV size E2V24CWAC0.
----- KIT-CO2-PANEL-C-03	----- KIT-CO2-PANEL-C-05	----- KIT-CO2-PANEL-C-09	----- KIT-CO2-PANEL-C-11	----- KIT-CO2-PANEL-C-14	----- KIT-CO2-PANEL-C-18	----- KIT-CO2-PANEL-C-24



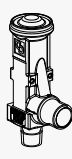
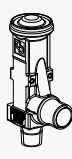

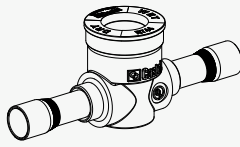
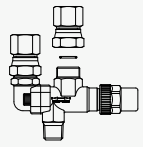
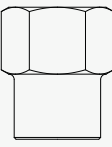

## Accessories

 <p><b>Service adaptor for vacuum and service (HP and LP port) for all outdoor units*.</b></p> <p>----- SPK-TU125</p>	 <p><b>Lubrication Oil PZ-68S (0,5L) for all outdoor units**.</b></p> <p>----- CZ-CO2LBR0L500</p>	 <p><b>NEW Pressure release valve (PRV) 3/8" (9,52) NPT x G 1/2" (12,70) Pset= 80,0 bar (PRV for suction line all outdoor units or PRV for liquid receiver only for 400VF8(A) and 1000VF8(A).</b></p> <p>----- PAW-CO2-PRV80</p>	 <p><b>NEW Pressure release valve (PRV) 3/8" (9,52) NPT x G 1/2" (12,70) Pset= 120,0 bar (PRV for liquid receiver, only for the 200VF5A).</b></p> <p>----- PAW-CO2-PRV120</p>
--	--	---	--

 <p><b>NEW Sight glass, 130 bar, 1/4" (6,35) ODS.</b></p> <p>----- PAW-SGT-GLASS-1/4</p>	<p><b>NEW Sight glass, 130 bar, 3/8" (9,52) ODS.</b></p> <p>----- PAW-SGT-GLASS-3/8</p>	<p><b>NEW Sight glass, 130 bar, 1/2" (12,70) ODS.</b></p> <p>----- PAW-SGT-GLASS-1/2</p>	<p><b>NEW Sight glass, 130 bar, 5/8" (15,88) - 16 mm ODS.</b></p> <p>----- PAW-SGT-GLASS-5/8</p>	<p><b>NEW Sight glass, 130 bar, 3/4" (19,05) ODS.</b></p> <p>----- PAW-SGT-GLASS-3/4</p>	 <p><b>NEW Changeover valve, 3/8" (9,52) NPT x 3/8" (9,52) NPT.</b></p> <p>----- PAW-CO2-CHANGE-0</p>	 <p><b>NEW Racord, 3/8" (9,52) NPT x 3/4" (19,05) ODS (to connect K65 3/4" (19,05)).</b></p> <p>----- PAW-CO2-RACORD-3/4</p>
--	---	--	--	--	--	---

### CO<sub>2</sub> service checker

### Spare parts for service and maintenance

 <p><b>CO<sub>2</sub> service checker for commissioning, maintenance and troubleshooting.</b></p> <p>----- PAW-CO2-CHECKER</p>	 <p><b>S-008T Suction filter, 3/4" (19,05) (outer Ø welding) for 400VF8(A), 1000VF8(A) and 2000VF8A.</b></p> <p>----- 80203514138000 <sup>1)</sup></p>	 <p><b>S-008T1 Suction filter, 3/4" (19,05) (outer Ø welding) for 400VF8(A), 1000VF8(A) and 2000VF8A.</b></p> <p>----- 80203514139000 <sup>2)</sup></p>	 <p><b>D-155T Filter dryer, 5/8" (15,88) (in Ø welding) (type CO-085-S) for 1000VF8(A) and 2000VF8A.</b></p> <p>----- 80203513180000 <sup>3)</sup></p>	 <p><b>DCY-P8 165 S Filter dryer, 5/8" (16,10) (in Ø welding) for 1000VF8(A) and 2000VF8A.</b></p> <p>----- 80203513187000 <sup>4)</sup></p>	 <p><b>D-152T Filter dryer, 1/4" (6,35) (in Ø welding) (type CO-082-S) for 200VF5A and 400VF8(A).</b></p> <p>----- 80203513179000 <sup>5)</sup></p>	 <p><b>DCY-P12 092 S Filter dryer, 1/4" (6,40) (in Ø welding) for 200VF5A and 400VF8(A).</b></p> <p>----- 80203513186000 <sup>6)</sup></p>
---	---	--	--	---	--	---

\* 2 pcs. are recommended for the 2000VF8A. \*\* You can find the PZ-68S oil "Safety Sheet" in the SAFETY section of our pipe selection software, available on our PRO Club platform.

Compatibility relationship: 1) and 2) are compatible; 3) and 4) are compatible; 5) and 6) are compatible. Stock availability: 1), 3) and 5) until end of stock.

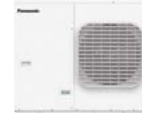
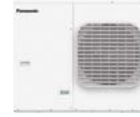
CO<sub>2</sub> condensing units - CR Series

Standard outdoor unit			OCU-CR200VF5A	OCU-CR400VF8	OCU-CR400VF8A		
Anti corrosion coating outdoor unit			OCU-CR200VF5ASL	OCU-CR400VF8SL	OCU-CR400VF8ASL		
Type (MT: medium temperature, LT: low temperature)			MT (4 kW) / LT (2 kW)	MT (7,5 kW)	MT (8 kW) / LT (4 kW)		
Power supply	Voltage	V	220/230/240	380/400/415	380/400/415		
	Phase		Single phase	Three phase	Three phase		
	Frequency	Hz	50	50	50		
Cooling capacity at ET -10 °C AT 32 °C		kW	3,70	6,89	7,52		
Cooling capacity at ET -35 °C AT 32 °C		kW	1,80	—	3,77		
<b>SEPR cooling at ET -10 °C AT 32 °C</b>			<b>3,83</b>	<b>3,17</b>	<b>3,20</b>		
<b>SEPR freezing at ET -35 °C AT 32 °C</b>			<b>1,92</b>	<b>—</b>	<b>1,73</b>		
Annual electricity consumption at ET -10 °C AT 32 °C		kWh/a	6797	13384	14488		
Annual electricity consumption at ET -35 °C AT 32 °C		kWh/a	8021	—	16255		
Evaporator connection			Multiple	Multiple	Multiple		
Evaporation temperature	Min ~ Max	°C	-45 ~ -5	-20 ~ -5	-45 ~ -5		
Ambient temperature	Min ~ Max	°C	-20 ~ +43	-20 ~ +45	-20 ~ +45		
Refrigerant			R744	R744	R744		
Design pressure liquid line		Mpa	12	8	8		
Design pressure suction line		Mpa	8	8	8		
User system external alarm. Digital input. Non-voltage contact			Yes	Yes	Yes		
Liquid tube electromagnetic valve		Vac	220/230/240	220/230/240	220/230/240		
Showcase operation ON / OFF signal. Digital input. Non-voltage contact			Yes	Yes	Yes		
Modbus communication line (RS485)		Ports	Yes	Yes	Yes		
Compressor type			2- stage rotary	2- stage rotary	2- stage rotary		
Dimension	H x W x D	mm	930 x 900 x 437	948 x 1143 x 609	948 x 1143 x 609		
Net weight		Kg	70	136	149		
Piping diameter <sup>1)</sup>	Suction pipe	Inch (mm)	¾(9,52)	½(12,70)	½(12,70)		
	Liquid pipe	Inch (mm)	¼(6,35)	¾(9,52)	¾(9,52)		
Length of connection piping		m	25	50 <sup>2)</sup>	50 <sup>2)</sup>		
PED		CAT	I	II	II		
Air flow		m <sup>3</sup> /min	54	59	59		
External static pressure		Pa	17	50	50		
Heat recovery port			—	—	Yes		
Standard performance	Ambient temperature	°C	32	32	32		
	Evaporating temperature	°C	-10	-35	-10	-35	
	Cooling capacity	kW	3,70	1,80	6,89	7,52	3,77
	Power consumption	kW	1,79	1,65	4,00	4,51	3,69
	Nominal load ampere	A	7,94	7,26	6,14	7,20	6,20
	Sound pressure	dB(A)	35,5 <sup>4)</sup>	35,5 <sup>4)</sup>	33,0 <sup>5)</sup>	36,1 <sup>5)</sup>	36,1 <sup>5)</sup>
<b>Necessary accessories</b>							
Drier filter liquid line, Ø6,35 mm		<b>D-152T / DCY-P12</b>	Yes (included)	Yes (included)	Yes (included)		
Drier filter liquid line, Ø15,88 mm		<b>D-155T / DCY-P8</b>	—	—	—		
Suction filter, Ø19,05 mm (outer Ø welding)		<b>S-008T / S-008T1</b>	—	Yes (included)	Yes (included)		

1) These diameters correspond to the output of the unit. The required diameter must be calculated with Refrigeration designer available on PRO Club. 2) PZ-68S (refrigeration oil) must be added according to Refrigeration designer available on PRO Club. 3) PZ-68S (refrigeration oil) must be added if >50 m. 4) ET-10 °C, 65 S-1, 10 m from product. 5) ET-10 °C, 80 S-1, 10 m from product. 6) ET -10 °C, 60 S-1, 10 m from product.







Standard outdoor unit			OCU-CR1000VF8	OCU-CR1000VF8A	OCU-CR2000VF8A*
Anti corrosion coating outdoor unit			OCU-CR1000VF8SL	OCU-CR1000VF8ASL	OCU-CR2000VF8ASL*
Type (MT: medium temperature, LT: low temperature)			MT (15 kW)	MT (16 kW) / LT (8 kW)	MT (29 kW) / LT (15 kW)
Power supply	Voltage	V	380/400/415	380/400/415	380/400/415
	Phase		Three phase	Three phase	Three phase
	Frequency	Hz	50	50	50
Cooling capacity at ET -10 °C AT 32 °C		kW	14,00	15,10	28,74
Cooling capacity at ET -35 °C AT 32 °C		kW	—	8,00	14,73
<b>SEPR cooling at ET -10 °C AT 32 °C</b>			<b>2,62</b>	<b>2,86</b>	<b>3,10</b>
<b>SEPR freezing at ET -35 °C AT 32 °C</b>			<b>—</b>	<b>1,49</b>	<b>1,64</b>
Annual electricity consumption at ET -10 °C AT 32 °C		kWh/a	32815	32409	57076
Annual electricity consumption at ET -35 °C AT 32 °C		kWh/a	—	39985	66760
Evaporator connection			Multiple	Multiple	Multiple
Evaporation temperature	Min - Max	°C	-20 ~ -5	-45 ~ -5	-45 ~ -5
Ambient temperature	Min - Max	°C	-20 ~ +43	-20 ~ +43	-20 ~ +45
Refrigerant			R744	R744	R744
Design pressure liquid line		Mpa	8	8	8
Design pressure suction line		Mpa	8	8	8
User system external alarm. Digital input. Non-voltage contact			Yes	Yes	Yes
Liquid tube electromagnetic valve		Vac	220/230/240	220/230/240	—
Showcase operation ON / OFF signal. Digital input. Non-voltage contact			Yes	Yes	Yes
Modbus communication line (RS485)		Ports	Yes	Yes	Yes
Compressor type			2- stage rotary	2- stage rotary	2- stage rotary
Dimension	HxWxD	mm	1941x890x890	1941x890x890	1941x1190x890
Net weight		Kg	293	320	494
Piping diameter <sup>1)</sup>	Suction pipe	Inch (mm)	¾(19,05)	¾(19,05)	1(25,40)
	Liquid pipe	Inch (mm)	¾(15,88)	¾(15,88)	¾(19,05)
Length of connection piping		m	100 <sup>3)</sup>	100 <sup>3)</sup>	100 <sup>3)</sup>
PED		CAT	II	II	II
Air flow		m <sup>3</sup> /min	220	220	220
External static pressure		Pa	58	58	58
Heat recovery port			—	Yes	Yes
Standard performance	Ambient temperature	°C	32	32	32
	Evaporating temperature	°C	-10	-10 -35	-10 -35
	Cooling capacity	kW	14,00	15,10 8,00	28,74 14,73
	Power consumption	kW	8,20	8,20 7,57	15,67 13,45
	Nominal load ampere	A	12,60	12,60 11,60	24,31 20,49
	Sound pressure	dB(A)	36,0 <sup>4)</sup>	36,0 <sup>4)</sup> 36,0 <sup>4)</sup>	38,9 <sup>4)</sup> 38,9 <sup>4)</sup>
<b>Necessary accessories</b>					
Drier filter liquid line, Ø6,35 mm		<b>D-152T / DCY-P12</b>	—	—	—
Drier filter liquid line, Ø15,88 mm		<b>D-155T / DCY-P8</b>	Yes (included)	Yes (included)	Yes (included)
Suction filter, Ø19,05 mm (outer Ø welding)		<b>S-008T / S-008T1</b>	Yes (included)	Yes (included)	Yes (included)

1) These diameters correspond to the output of the unit. The required diameter must be calculated with Refrigeration designer available on PRO Club. 2) PZ-68S (refrigeration oil) must be added according to Refrigeration designer available on PRO Club. 3) PZ-68S (refrigeration oil) must be added if >50 m. 4) ET-10 °C, 65 S-1, 10 m from product. 5) ET-10 °C, 80 S-1, 10 m from product. 6) ET -10 °C, 60 S-1, 10 m from product. \* Available in Summer 2024. Tentative data.



# Panasonic PACi NX Elite can cool rooms down to 8 °C

PACi

Panasonic PACi NX Elite offers a high quality and efficient solution for high temperature refrigeration applications for facilities such as wine cellars, food processing facilities and supermarkets.

Cooling rooms between  
8 °C WB and 24 °C WB





## Solutions for cold rooms. Set the room temperature to 8 °C.

Complete range from 2,1 to 23,2 kW. This unique solution is perfect for:

Wine cellars, ice cream factories, flower shops, supermarkets, grain stores, food storage, food processing, food distribution, lunchrooms, vegetable processing...

Just like all the indoor units in the PACi NX range, these units are compatible with all Panasonic control and monitoring solutions, which can be scaled from controlling a single zone to monitoring geographically distributed facilities.

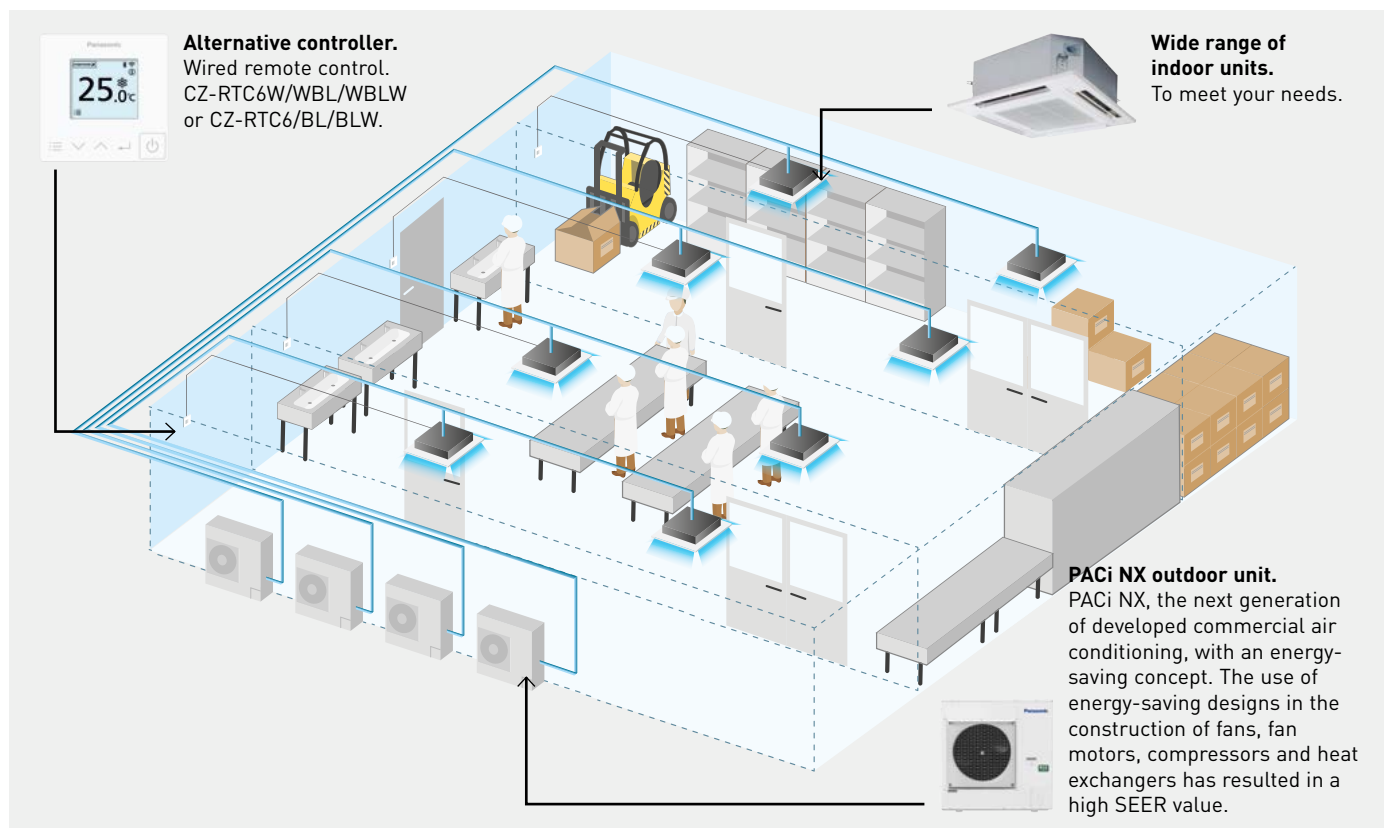

- Flexibility with different type of indoors
- Benefits of hydroxyl radicals
- Out of the box solution from Panasonic. Outdoor, indoor, controller comes as package
- Provides wide scale of control options (individual, central, cloud)
- Redundancy for 2 systems with CONEX controller range and up to 4 indoor unit groups with PAW-PACR4 optional redundancy controller



## Wine cellars and special high temperature rooms

One of the main features of the PACi NX series is the possibility of adjusting the product for special applications, not just for regular cooling applications. The purpose of this product information is to explain in detail these special applications that need a cooling operation to maintain the room temperature at +8 ~ +24 °C WB (or +10 ~ +30 °C DB). In order to do this in terms of enthalpy, the indoor unit needs to be oversized and certain parameters need to be adjustable.

Temperature range for wine cellar		
	Indoor	Outdoor
Cooling operation	+8 ~ +24 °C WB	-5 [-15] ~ 43 °C DB

**Temperature range for wine cellar.**  
In cooling. Outdoor air intake temperature °C DB.

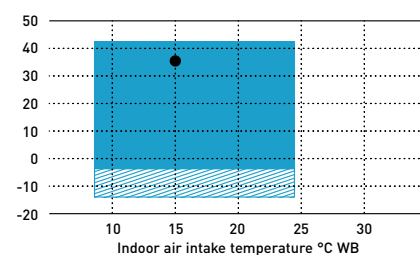

 Only allowed after installation of wind and snow vents.

 Area where cooling capacity is established for this purpose.

# Bringing nature's balance indoors



## nanoe™ X, technology with the benefits of hydroxyl radicals.

Abundant in nature, hydroxyl radicals (also known as OH radicals) have the capacity to inhibit pollutants, viruses, and bacteria to clean and deodorise. nanoe™ X technology can bring these incredible benefits indoors so that hard surfaces, soft furnishings, and the indoor environment can be a cleaner and more pleasant place to be.



### What is unique about nanoe™ X?

**Effective on fabrics and surfaces.**

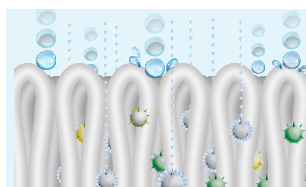

1 | At one billionth of a metre, nanoe™ X is much smaller than steam and can deeply penetrate cloth fabrics to deodorise.

**Longer lifespan.**



2 | Contained in tiny water particles, nanoe™ X has a long lifespan, which is about 600 seconds, to spread easily around the room.

**Huge quantity.**



3 | nanoe X Generator Mark 3 produces 48 trillion hydroxyl radicals per second. Greater amounts of hydroxyl radicals contained in nanoe™ X lead to higher performance on inhibition of pollutants.

**Maintenance-free.**

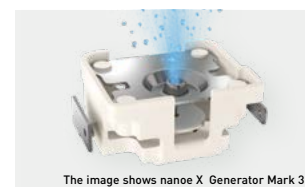

The image shows nanoe X Generator Mark 3.

4 | No service and maintenance required. nanoe™ X is a filter free solution that does not require maintenance, as its atomisation electrode is enveloped with water during its generation process and it is made with Titanium.

### 7 effects of nanoe™ X – Panasonic unique technology

**Deodorises**



Odours

**Capacity to inhibit 5 types of pollutants**

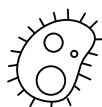

Bacteria and viruses

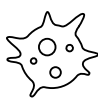

Mould



Allergens



Pollen



Hazardous substances



Skin and hair

\* Refer to <https://aircon.panasonic.eu> for more details and validation data.

### First nanoe™ device was developed by Panasonic in 2003

**Generator: nanoe™**

2003

480 billion hydroxyl radicals/sec

**Ion particle structure**

Hydroxyl radicals

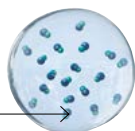

**Generator: nanoe™ X**

**Mark 1 - 2016**

4,8 trillion hydroxyl radicals/sec

10x times

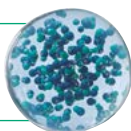

**Mark 2 - 2019**

9,6 trillion hydroxyl radicals/sec

20x times

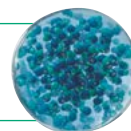

**Mark 3 - 2022**

48 trillion hydroxyl radicals/sec

100x times

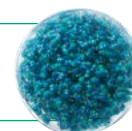



## nanoe™ X, internationally-validated technology in testing facilities.

The effectiveness of nanoe™ X technology has been tested by 3rd party laboratories in Germany, France, Denmark, Japan and China.

The nanoe™ X performance varies depending on the room size, environment and usage and it may take several hours to reach the full effect. nanoe™ X is not medical device, local regulations on building design and sanitary recommendations must be followed. Test results conducted under controlled laboratory conditions. Performance of nanoe™ X might differ in real life environment.

	Tested contents	Generator	Result	Capacity	Time	Testing organisation	Report No.	
Airborne	Virus	Influenza (H1N1)	Mark 2	98,3% inhibited	30 m³	1,5 h	China Electronic Product Reliability and Environmental Testing Research Institute	J2003WT8888-00889
		Bacteriophage ΦX174	Mark 1	99,2% inhibited	Approx. 25 m³	6 h	Kitasato Research Center for Environmental Science	24_0300_1
	Bacteria	Staphylococcus aureus	Mark 1	99,7% inhibited	Approx. 25 m³	4 h	Kitasato Research Center for Environmental Science	24_0301_1
Adhering	Virus	SARS-CoV-2	Mark 1	91,4% inhibited	6,7 m³	8 h	Texcell (France)	1140-01 C3
		SARS-CoV-2	Mark 1	99,9% inhibited	45 L	2 h	Texcell (France)	1140-01 A1
		Bacteriophage ΦX174	Mark 1	99,8% inhibited	Approx. 25 m³	8 h	Japan Food Research Laboratories	13001265005-01
		Xenotropic murine leukemia virus	Mark 1	99,999% inhibited	45 L	6 h	Charles River Biopharmaceutical Services GmbH	—
		Coxsackie virus (CA16)	Mark 2	99,9%inhibited	30 m³	4 h	China Electronic Product Reliability and Environmental Testing Research Institute	J2002WT8888-00439
		Bacteriophage	Mark 3	98,81% inhibited	Approx. 139,3 m³	4 h	SGS Inc	SHES210901902584
	Bacteria	Staphylococcus aureus	Mark 1	99,9% inhibited	20 m³	8 h	Danish Technological Institute	868988
			Mark 3	99%inhibited	Approx. 24 m³	12 h	Panasonic Product Analysis Center	H21YA017-1
		Ambrosia pollen	Mark 1	99,4% inhibited	20 m³	8 h	Danish Technological Institute	868988
	Odours	Cigarette smoke odour	Mark 1	Odour intensity reduced by 2,4 levels	Approx. 23 m³	0,2 h	Panasonic Product Analysis Center	4AA33-160615-N04
			Mark 3	Odour intensity reduced 1,7 levels	Approx. 139,3 m³	0,5 h	SGS Inc	SHES210901902478

### Licensed in VDI 6022

Certification of a HVAC system under VDI 6022 guarantees that the system fulfills the market's strictest hygiene requirements.



#### VDI 6022 – Part 5 <sup>1)</sup> Certification.

##### Avoidance of allergenic exposure.

Inhibits a wide range of harmful bacteria, viruses, mould, pollen and allergens.



#### VDI 6022 – Part 1 <sup>1)</sup> & 1.1 <sup>2)</sup> Certification.

##### Ventilation and indoor-air quality.

Panasonic nanoe™ X technology improving indoor air quality.

1) Certification mark only valid for nanoe X Generator Mark 3. 2) Certification mark only valid for nanoe X Generator Mark 2 and Mark 3.

## nanoe™ X: improving protection 24/7



Acts to clean the work area, such as meat or fish handling in hotel kitchens, food handling in industrial processes, laboratories, wine cellars, etc. So that the indoor environment can be a cleaner and more pleasant place to be all day long and keep the processes in better bacterial conditions.

nanoe™ X works together with the cooling function when during the day but can work independently when the area is not occupied.

Give the system the strength to increase the protection of persons, air, colds stuffs and working surfaces with nanoe™ X technology and convenient control via the Panasonic Comfort Cloud App.

#### Cleans the air even when there is no work activity.

Leave the nanoe™ X mode ON to inhibit certain pollutants and deodorize before start the work activity again.

#### Improves your environment and better protects the products handled when you are or not at work.

Enjoy a cleaner comfortable space both when working indoors and simply when it comes to better protecting products in the cold room.



### Panasonic Heating & Cooling Solutions is incorporating nanoe™ technology in a wide range of equipment

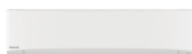

**Wall-mounted.  
Built-in nanoe X Generator Mark 2.**



**Ceiling.  
Built-in nanoe X Generator Mark 2.**



**4 Way 90x90 cassette.  
Built-in nanoe X Generator Mark 1.**



**Adaptive ducted unit.  
Built-in nanoe X Generator Mark 2.**

## PACi NX Series Elite wall-mounted - PK3 · R32

For light refrigeration applications.



nanoe™ X as a standard.



		High temperature								
Kit		36	50	60	71	100	125	140		
Indoor unit - 1		S-6010PK3E	S-6010PK3E	S-6010PK3E	S-6010PK3Ex2	S-6010PK3E	S-6010PK3E	S-6010PK3E	S-6010PK3E	
Indoor unit - 2						S-6010PK3E	S-6010PK3E	S-6010PK3E	S-6010PK3E	
Outdoor unit		U-36PZH3E5	U-50PZH3E5	U-60PZH3E5	U-71PZH4E5/8	U-100PZH4E5/8	U-125PZH4E5/8	U-140PZH4E5/8		
Outdoor 35 °C (DB)	Indoor 15 °C (WB)	Cooling capacity	kW	3,50	4,90	5,80	6,90	8,80	11,60	13,00
		EER		4,55	3,83	3,56	3,17	2,97	3,06	3,34
		Input power	kW	0,77	1,28	1,63	2,18	2,96	3,79	3,89
	Indoor 12 °C (WB)	Cooling capacity	kW	3,19	4,46	5,28	6,28	8,01	10,56	11,83
		EER		4,22	3,55	3,30	2,94	2,76	2,84	3,10
		Input power	kW	0,75	1,25	1,60	2,14	2,90	3,71	3,81
	Indoor 8 °C (WB)	Cooling capacity	kW	2,10	2,94	3,27	4,14	5,28	6,96	7,80
		EER		3,50	2,94	2,14	2,44	2,28	2,35	2,57
		Input power	kW	0,60	1,00	1,52	1,70	2,31	2,96	3,03
Outdoor 30 °C (DB)	Indoor 15 °C (WB)	Cooling capacity	kW	3,75	5,24	5,92	7,04	9,42	12,41	13,91
		EER		5,29	4,45	3,86	3,44	3,45	3,56	3,88
		Input power	kW	0,71	1,18	1,53	2,05	2,72	3,49	3,58
	Indoor 12 °C (WB)	Cooling capacity	kW	3,43	4,80	5,39	6,42	8,62	11,37	12,74
		EER		4,95	4,17	3,60	3,20	3,23	3,33	3,64
		Input power	kW	0,69	1,15	1,50	2,01	2,66	3,41	3,50
	Indoor 8 °C (WB)	Cooling capacity	kW	2,10	2,94	3,48	4,14	5,28	6,96	7,80
		EER		3,90	3,28	2,97	2,64	2,55	2,62	2,86
		Input power	kW	0,54	0,90	1,17	1,57	2,16	2,65	2,72
Indoor unit	Dimension (HxWxD)	mm	302 x 1120 x 236	302 x 1120 x 236	302 x 1120 x 236	302 x 1120 x 236	302 x 1120 x 236	302 x 1120 x 236	302 x 1120 x 236	
	Net weight	kg	14	14	14	14	14	14	14	
	nanoe X Generator		Mark 2	Mark 2	Mark 2	Mark 2	Mark 2	Mark 2	Mark 2	
Outdoor unit	Dimension (HxWxD)	mm	695 x 875 x 320	695 x 875 x 320	695 x 875 x 320	996 x 980 x 370	996 x 980 x 370	996 x 980 x 370	996 x 980 x 370	
	Net weight	kg	42	42	43	66	84	86	86	

## Accessories

<b>CZ-RTC6W</b>	CONEX wired remote controller (non-wireless), white
<b>CZ-RTC6WBL</b>	CONEX wired remote controller with Bluetooth®, white
<b>CZ-RTC6WBLW</b>	CONEX wired remote controller with Wi-Fi and Bluetooth®, white
<b>CZ-RTC6</b>	CONEX wired remote controller (non-wireless), black
<b>CZ-RTC6BL</b>	CONEX wired remote controller with Bluetooth®, black
<b>CZ-RTC6BLW</b>	CONEX wired remote controller with Wi-Fi and Bluetooth®, black
<b>CZ-RTC5B</b>	Wired remote controller with Econavi function and datanavi
<b>CZ-RWS3</b>	Infrared remote controller

## Accessories

<b>PAW-PACR4</b>	Interface to run up to 4 indoor unit groups on backup and alternative run
<b>PAW-WTRAY</b>	Tray for condenser water compatible with outdoor elevation platform
<b>PAW-GRDBSE20</b>	Outdoor base ground support for noise and vibration absorption
<b>PAW-GRDSTD40</b>	Outdoor elevation platform 400 x 900 x 400 mm
<b>CZ-CENSC1</b>	Econavi energy saving sensor

## Technical focus

- Modern design with flat face and compact size
- DC fan for better efficiency and control
- Six directional piping outlet
- nanoe™ X (Generator Mark 2: 9,6 trillion hydroxyl radicals/sec) as standard for better indoor air quality
- Wired remote control CZ-RTC6WBL and CZ-RTC6BL allows easy system setting via Bluetooth®
- Easy connection and control of external fan or ERV using the connector PAW-FDC on the indoor unit PCB. The external device can be controlled by the remote control of the Panasonic indoor unit

## Closed discharge port

When the unit is turned OFF, the flap closes completely to prevent dust getting into the unit and to keep the equipment clean.

## Quiet operation

These units are among the quietest in the industry, making them ideal for all types of installations.

## Piping outlet in six directions

Piping outlet is possible in six directions of; right, right rear, right bottom, left, left rear and left bottom, making the installation work more flexible.

## PACi NX Series Elite 4 way 90x90 cassette - PU3 · R32

For light refrigeration applications.



nanoe™ X as a standard.

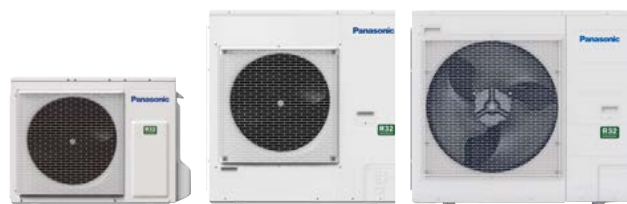

Kit			High temperature									
			36	50	60	71	100	125	140	200	250	
Indoor unit - 1			S-6071PU3E	S-6071PU3E	S-1014PU3E	S-1014PU3E	S-1014PU3E	S-1014PU3E	S-1014PU3E	S-1014PU3E	S-1014PU3E	
Indoor unit - 2			—	—	—	—	—	—	S-1014PU3E	S-1014PU3E	S-1014PU3E	
Outdoor unit			U-36PZH3E5	U-50PZH3E5	U-60PZH3E5	U-71PZH4E5/8	U-100PZH4E5/8	U-125PZH4E5/8	U-140PZH4E5/8	U-200PZH4E8	U-250PZH4E8	
Outdoor 35 °C (DB)	Indoor 15 °C (WB)	Cooling capacity	kW	3,50	4,90	5,80	6,90	8,80	11,60	13,00	18,50	23,20
		EER		5,12	4,05	3,81	3,67	4,09	3,47	3,82	3,38	2,97
		Input power	kW	0,68	1,21	1,52	1,88	2,15	3,34	3,40	5,48	7,82
	Indoor 12 °C (WB)	Cooling capacity	kW	3,19	4,46	5,28	6,28	8,01	10,56	11,83	16,84	21,11
		EER		4,78	3,76	3,54	3,41	3,80	3,22	3,55	3,13	2,75
		Input power	kW	0,67	1,19	1,49	1,84	2,11	3,27	3,33	5,37	7,66
	Indoor 8 °C (WB)	Cooling capacity	kW	2,10	2,94	3,48	4,14	5,28	6,96	7,80	11,10	13,92
		EER		3,96	3,12	2,94	2,82	3,15	2,67	2,94	2,60	2,28
		Input power	kW	0,53	0,94	1,19	1,47	1,68	2,61	2,65	4,27	6,10
Outdoor 30 °C (DB)	Indoor 15 °C (WB)	Cooling capacity	kW	3,75	5,24	5,92	7,04	9,42	12,41	13,91	20,17	25,29
		EER		5,99	4,71	4,14	3,98	4,76	4,04	4,45	4,00	3,51
		Input power	kW	0,63	1,11	1,43	1,77	1,98	3,07	3,13	5,04	7,19
	Indoor 12 °C (WB)	Cooling capacity	kW	3,43	4,80	5,39	6,42	8,62	12,41	12,74	18,50	23,20
		EER		5,60	4,41	3,86	3,71	4,46	4,04	4,16	3,75	3,30
		Input power	kW	0,61	1,09	1,40	1,73	1,94	3,07	3,06	4,93	7,04
	Indoor 8 °C (WB)	Cooling capacity	kW	2,10	2,94	3,48	4,14	5,28	6,96	7,80	11,10	13,92
		EER		4,41	3,47	3,18	3,06	3,51	2,98	3,28	2,89	2,54
		Input power	kW	0,48	0,85	1,09	1,35	1,51	2,34	2,38	3,84	5,47
Indoor unit	Dimension (HxWxD)	mm	256x840x840	256x840x840	256x840x840	319x840x840	319x840x840	319x840x840	319x840x840	319x840x840	319x840x840	
	Net weight	kg	19	19	20	25	25	25	25	25	25	
	nanoe X Generator		Mark 1	Mark 1	Mark 1	Mark 1	Mark 1	Mark 1	Mark 1	Mark 1	Mark 1	
Outdoor unit	Dimension (HxWxD)	mm	695x875x320	695x875x320	695x875x320	996x980x370	996x980x370	996x980x370	996x980x370	996x1140x460	996x1140x460	
	Net weight	kg	42	42	43	66	84	86	86	—	—	

### Accessories

<b>CZ-RTC6W</b>	CONEX wired remote controller (non-wireless), white
<b>CZ-RTC6WBL</b>	CONEX wired remote controller with Bluetooth®, white
<b>CZ-RTC6WBLW</b>	CONEX wired remote controller with Wi-Fi and Bluetooth®, white
<b>CZ-RTC6</b>	CONEX wired remote controller (non-wireless), black
<b>CZ-RTC6BL</b>	CONEX wired remote controller with Bluetooth®, black
<b>CZ-RTC6BLW</b>	CONEX wired remote controller with Wi-Fi and Bluetooth®, black
<b>CZ-RTC5B</b>	Wired remote controller with Econavi function and datanavi

### Accessories

<b>CZ-RWS3 + CZ-RWRU3W</b>	Infrared remote controller and receiver
<b>CZ-KPU3AW</b>	Econavi exclusive panel
<b>PAW-WTRAY</b>	Tray for condenser water compatible with outdoor elevation platform
<b>PAW-GRDBSE20</b>	Outdoor base ground support for noise and vibration absorption
<b>PAW-GRDSTD40</b>	Outdoor elevation platform 400x900x400 mm
<b>CZ-FDU3+CZ-ATU2</b>	Fresh air-intake kit

### Technical focus

- High performance turbo fan
- Econavi: An optional intelligent sensor to reduce waste of energy
- nanoe™ X (Generator Mark 1: 4,8 trillion hydroxyl radicals/sec) as standard for better indoor air quality, indoor unit internal cleaning with nanoe™ X plus dry operation
- Lower noise in low fan operation
- Light weight, easy piping and integrated drain pump for quick installation
- Wired remote control CZ-RTC6WBL and CZ-RTC6BL allows easy system setting via Bluetooth®
- High volume fresh air input with optional air-intake plenum and chamber (CZ-FDU3+CZ-ATU2)



## PACi NX Series Elite ceiling - PT3 · R32

For light refrigeration applications.



nanoe™ X as a standard.

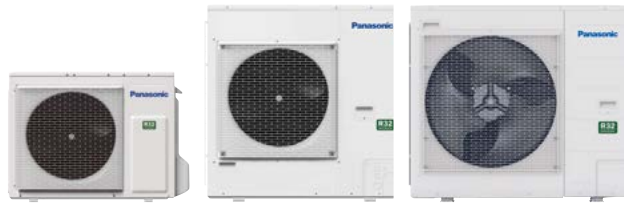

		High temperature										
Kit		36	50	60	71	100	125	140	200	250		
Indoor unit - 1		S-6071PT3E	S-6071PT3E	S-1014PT3E	S-1014PT3E	S-1014PT3E	S-1014PT3E	S-1014PT3E	S-1014PT3E	S-1014PT3E		
Indoor unit - 2		—	—	—	—	—	—	S-1014PT3E	S-1014PT3E	S-1014PT3E		
Outdoor unit		U-36PZH3E5	U-50PZH3E5	U-60PZH3E5	U-71PZH4E5/8	U-100PZH4E5/8	U-125PZH4E5/8	U-140PZH3E5/8	U-200PZH4E8	U-250PZH4E8		
Outdoor 35 °C (DB)	Indoor 15 °C (WB)	Cooling capacity	kW	3,50	4,90	5,80	6,60	8,80	11,20	13,00	18,50	23,20
		EER		4,67	3,71	3,63	3,53	3,76	3,15	3,40	3,32	2,92
		Input power	kW	0,75	1,32	1,60	1,87	2,34	3,56	3,82	5,57	7,94
	Indoor 12 °C (WB)	Cooling capacity	kW	3,19	4,46	5,28	6,01	8,01	10,19	11,83	16,84	21,11
		EER		4,33	3,45	3,37	3,28	3,49	2,92	3,16	3,08	2,71
		Input power	kW	0,74	1,29	1,57	1,83	2,29	3,49	3,74	5,46	7,78
	Indoor 8 °C (WB)	Cooling capacity	kW	2,10	2,94	3,48	3,96	5,28	6,72	7,80	11,10	13,92
		EER		3,59	2,86	2,79	2,71	2,89	2,42	2,62	2,55	2,25
		Input power	kW	0,59	1,03	1,25	1,46	1,83	2,78	2,98	4,34	6,19
Outdoor 30 °C (DB)	Indoor 15 °C (WB)	Cooling capacity	kW	3,75	5,24	5,92	6,73	9,42	11,98	13,91	20,17	25,29
		EER		5,43	4,32	3,93	3,83	4,37	3,66	3,96	3,94	3,46
		Input power	kW	0,69	1,21	1,50	1,76	2,15	3,28	3,51	5,12	7,30
	Indoor 12 °C (WB)	Cooling capacity	kW	3,43	4,80	5,39	6,14	8,62	10,98	12,74	18,50	23,20
		EER		5,08	4,04	3,66	3,57	4,09	3,43	3,71	3,69	3,25
		Input power	kW	0,68	1,19	1,47	1,72	2,11	3,20	3,44	5,01	7,15
	Indoor 8 °C (WB)	Cooling capacity	kW	2,10	2,94	3,48	3,96	5,28	6,72	7,80	11,10	13,92
		EER		4,00	3,18	3,02	2,94	3,22	2,70	2,92	2,85	2,50
		Input power	kW	0,53	0,92	1,15	1,35	1,64	2,49	2,67	3,90	5,56
Indoor unit	Dimension (HxWxD)	mm	235x1275x690	235x1275x690	235x1590x690	235x1590x690	235x1590x690	235x1590x690	235x1590x690	235x1590x690	235x1590x690	
	Net weight	kg	34	34	40	40	40	40	40	40	40	
	nanoe X Generator		Mark 2	Mark 2	Mark 2	Mark 2	Mark 2	Mark 2	Mark 2	Mark 2	Mark 2	
Outdoor unit	Dimension (HxWxD)	mm	695x875x320	695x875x320	695x875x320	996x980x370	996x980x370	996x980x370	996x980x370	996x1140x460	996x1140x460	
	Net weight	kg	42	42	43	66	84	86	86	—	—	

## Accessories

<b>CZ-RTC6W</b>	CONEX wired remote controller (non-wireless), white
<b>CZ-RTC6WBL</b>	CONEX wired remote controller with Bluetooth®, white
<b>CZ-RTC6WBLW</b>	CONEX wired remote controller with Wi-Fi and Bluetooth®, white
<b>CZ-RTC6</b>	CONEX wired remote controller (non-wireless), black
<b>CZ-RTC6BL</b>	CONEX wired remote controller with Bluetooth®, black
<b>CZ-RTC6BLW</b>	CONEX wired remote controller with Wi-Fi and Bluetooth®, black
<b>CZ-RTC5B</b>	Wired remote controller with Econavi function and datanavi

## Accessories

<b>CZ-RWS3 + CZ-RWRT3</b>	Infrared remote controller and receiver
<b>PAW-WTRAY</b>	Tray for condenser water compatible with outdoor elevation platform
<b>PAW-GRDBSE20</b>	Outdoor base ground support for noise and vibration absorption
<b>PAW-GRDSTD40</b>	Outdoor elevation platform 400x900x400 mm
<b>CZ-CENSC1</b>	Econavi energy saving sensor

## Technical focus

- Wide air distribution for large rooms
- Horizontal air flow reaches maximum 9,5 m
- Fresh air connection available on the unit
- Slim design with 235 mm height fits narrow space
- Silent operation
- nanoe™ X (Generator Mark 2: 9,6 trillion hydroxyl radicals/sec) as standard for better indoor air quality
- Wired remote control CZ-RTC6WBL and CZ-RTC6BL allows easy system setting via Bluetooth®
- Twin, Triple and Double-twin split options
- Easy connection and control of external fan or ERV using the connector PAW-FDC on the indoor unit PCB. The external device can be controlled by the remote control of the Panasonic indoor unit

## Further comfort improvement with air flow distribution

Horizontal air flow reaches maximum 9,5 m. This is ideal for wide rooms.

The wide air discharge opening expands the air flow to the left and right. The unpleasant feeling caused when the air flow directly hits the human body is prevented by the "Draft prevention position", which changes the swing width, increasing the degree of comfort.

## PACi NX Series Elite adaptive ducted unit - PF3 · R32

For light refrigeration applications.

**nanoe™ X**

nanoe™ X as a standard.

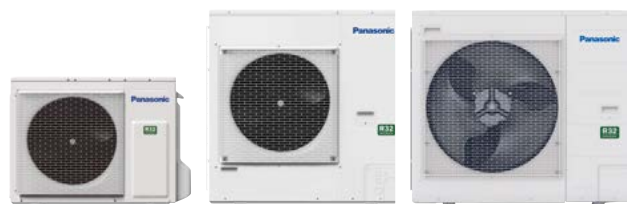

			High temperature										
Kit			36	50	60	71	100	125	140	200	250		
Indoor unit - 1			S-6071PF3E	S-6071PF3E	S-1014PF3E	S-1014PF3E	S-1014PF3E	S-1014PF3E	S-1014PF3E	S-1014PF3E	S-1014PF3E		
Indoor unit - 2			—	—	—	—	—	—	S-1014PF3E	S-1014PF3E	S-1014PF3E		
Outdoor unit			U-36PZH3E5	U-50PZH3E5	U-60PZH3E5	U-71PZH4E5/8	U-100PZH4E5/8	U-125PZH4E5/8	U-140PZH4E5/8	U-200PZH4E8	U-250PZH4E8		
Outdoor 35 °C (DB)	Indoor 15 °C (WB)	Cooling capacity	kW	3,50	4,90	5,80	6,60	8,80	11,20	13,00	18,50	23,20	
		EER		3,98	3,20	3,52	3,37	3,79	3,21	3,59	3,50	3,08	
		Input power	kW	0,88	1,53	1,65	1,96	2,32	3,49	3,62	5,29	7,54	
	Indoor 12 °C (WB)	Cooling capacity	kW	3,19	4,46	5,28	6,01	8,01	10,19	11,83	16,84	21,11	
		EER		3,69	2,97	3,26	3,13	3,52	2,98	3,33	3,25	2,86	
		Input power	kW	0,86	1,50	1,62	1,92	2,27	3,42	3,55	5,18	7,39	
	Indoor 8 °C (WB)	Cooling capacity	kW	2,10	2,94	3,48	3,96	5,28	6,72	7,80	11,10	13,92	
		EER		3,06	2,46	2,70	2,59	2,92	2,47	2,76	2,69	2,37	
		Input power	kW	0,69	1,19	1,29	1,53	1,81	2,72	2,82	4,13	5,88	
	Outdoor 30 °C (DB)	Indoor 15 °C (WB)	Cooling capacity	kW	3,75	5,24	5,92	6,73	9,42	11,98	13,91	20,17	25,29
			EER		4,63	3,72	3,81	3,65	4,41	3,73	4,18	4,14	3,65
			Input power	kW	0,81	1,41	1,55	1,84	2,13	3,21	3,33	4,87	6,94
Indoor 12 °C (WB)		Cooling capacity	kW	3,43	4,80	5,39	6,14	8,62	10,98	12,74	18,50	23,20	
		EER		4,33	3,49	3,55	3,40	4,13	3,49	3,91	3,89	3,42	
		Input power	kW	0,79	1,38	1,52	1,80	2,09	3,14	3,26	4,76	6,79	
Indoor 8 °C (WB)		Cooling capacity	kW	2,10	2,94	3,48	3,96	5,28	6,72	7,80	11,10	13,92	
		EER		3,41	2,75	2,93	2,81	3,25	2,75	3,08	3,00	2,64	
		Input power	kW	0,62	1,07	1,19	1,41	1,62	2,44	2,53	3,70	5,28	
Indoor unit			Dimension (HxWxD)	mm	250x1000x730	250x1000x730	250x1000x730	250x1400x730	250x1400x730	250x1400x730	250x1400x730	250x1400x730	
			Net weight	kg	30	30	30	39	39	39	39	39	
			nanoe X Generator		Mark 2	Mark 2	Mark 2	Mark 2	Mark 2	Mark 2	Mark 2	Mark 2	
Outdoor unit			Dimension (HxWxD)	mm	695x875x320	695x875x320	695x875x320	996x980x370	996x980x370	996x980x370	996x980x370	996x1140x460	
			Net weight	kg	42	42	43	66	84	86	84	—	

### Accessories

<b>CZ-RTC6W</b>	CONEX wired remote controller (non-wireless), white
<b>CZ-RTC6WBL</b>	CONEX wired remote controller with Bluetooth®, white
<b>CZ-RTC6WBLW</b>	CONEX wired remote controller with Wi-Fi and Bluetooth®, white
<b>CZ-RTC6</b>	CONEX wired remote controller (non-wireless), black
<b>CZ-RTC6BL</b>	CONEX wired remote controller with Bluetooth®, black
<b>CZ-RTC6BLW</b>	CONEX wired remote controller with Wi-Fi and Bluetooth®, black
<b>CZ-RTC5B</b>	Wired remote controller with Econavi function and datanavi
<b>CZ-RWS3 + CZ-RWRC3</b>	Infrared remote controller and receiver
<b>PAW-WTRAY</b>	Tray for condenser water compatible with outdoor elevation platform

### Technical focus

- 2 installation possibilities (horizontal / vertical)
- Maximum external static pressure: 150 Pa
- Selectable inlet air position (rear / bottom entry)
- Improved drain pan suitable for both horizontal / vertical installation
- Drain pump included
- nanoe™ X (Generator Mark 2: 9,6 trillion hydroxyl radicals/sec) as standard for the long duct piping case\*
- **NEW** BION air pollutant filter for certain types of pollutants, such as nitrogen dioxide (NO<sub>2</sub>), nitrogen oxides (NO<sub>x</sub>) and Ozone (O<sub>3</sub>) (optional)
- Wired remote control CZ-RTC6WBL and CZ-RTC6BL allows easy system setting via Bluetooth®

\* The performance of nanoe™ X air can be expected even by 10 m long duct by Panasonic internal survey.

### Accessories

<b>PAW-GRDBSE20</b>	Outdoor base ground support for noise and vibration absorption
<b>PAW-GRDSTD40</b>	Outdoor elevation platform 400x900x400 mm
<b>CZ-CENSC1</b>	Econavi energy saving sensor
<b>CZ-56DAF2</b>	Air outlet plenum for S-3650PF3E
<b>CZ-90DAF2</b>	Air outlet plenum for S-6071PF3E
<b>CZ-160DAF2</b>	Air outlet plenum for S-1014PF3E
<b>PAW-APF800F</b>	<b>NEW</b> BION air pollutant filter for S-3650PF3E
<b>PAW-APF1000F</b>	<b>NEW</b> BION air pollutant filter for S-6071PF3E
<b>PAW-APF1400F</b>	<b>NEW</b> BION air pollutant filter for S-1014PF3E

### 2 installation possibilities (horizontal / vertical)

Vertical installation is available. ESP 150Pa, sufficient for remotely installing units away from the rooms.



### Improved drain pan design

Drain pan is shared in both cases horizontal and vertical installation. No need to modify the unit.

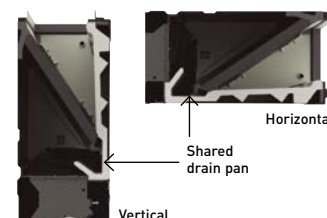

**Panasonic Marketing Europe GmbH**  
**Panasonic Heating & Ventilation Air-Conditioning Europe**

Hagenauer Strasse 43, 65203 Wiesbaden, Germany  
**www.aircon.panasonic.eu**

**Ireland**

**Panasonic Heating & Cooling Solutions**

1 The Courtyard, Kiltarbery Business Park, Nangor  
 Road, Dublin D22 R791, Ireland  
 ☎ 1800 939 977  
 www.aircon.panasonic.ie

**France / Belgium / Luxembourg**

**Panasonic Solutions Chauffage & Refroidissement**

1 à 7 Rue du 19 Mars 1962, 92238, Gennevilliers  
 Cedex, France  
 ☎ 0800 805 215 (France)  
 +32 2 320 55 38 (Belgium & Luxembourg)  
 www.aircon.panasonic.eu

**Germany / Austria / Switzerland**

**Panasonic Heiz- & Kühlsysteme**

Hagenauer Str. 43, 65203 Wiesbaden, Germany  
 +49 611 711 87 211 (Germany)  
 ☎ +43 1 253 22 120 (Austria)  
 +41 41 561 53 66 (Switzerland)  
 HLK-Support-DE@eu.panasonic.com (Germany)  
 ☎ HLK-Support-AT@eu.panasonic.com (Austria)  
 HLK-Support-CH@eu.panasonic.com (Switzerland)  
 www.aircon.panasonic.eu

**Poland**

**Panasonic Heating & Cooling Solutions**

Wotoska 9, 02-583, Warszawa, Polska  
 ☎ 800 080 911  
 ☎ info.pl@panasonicproclub.com  
 www.aircon.panasonic.pl

**The Netherlands**

**Panasonic Heating & Cooling Solutions**

Europalaan 28E, 5332 BC, 's-Hertogenbosch,  
 The Netherlands  
 ☎ +31 736 402 538  
 www.aircon.panasonic.nl

**Spain / Portugal**

**Panasonic Heating & Cooling Solutions**

WTC Almeda Park, plaza de la Pau s/n, Edificio 6,  
 planta 4ª, Local D - 08940 Cornellà de Llobregat,  
 Spain  
 ☎ 900 82 87 87 (Spain)  
 800 78 22 20 (Portugal)  
 www.aircon.panasonic.eu

**Italy / Malta / Cyprus / Greece**

**Panasonic Heating & Cooling Solutions**

Viale dell'Innovazione, 3, 20126, Milano, Italy  
 ☎ +39 02 6433235 (Customer Service)  
 www.aircon.panasonic.eu

**Sweden / Denmark / Norway / Finland**

**Panasonic Heating & Cooling Solutions**

Sundbybergsvägen 1, 171 73 Solna, Sweden  
 +46 85 221 81 00 (Sweden)  
 ☎ +45 89 87 45 00 (Denmark)  
 +47 69 67 61 00 (Norway)  
 +35 86 46 04 15 90 (Finland)  
 www.aircon.panasonic.eu

**Czech Republic / Slovakia**

**Panasonic Heating & Cooling Solutions**

Křižíkova 148/34, 186 00 Praha 8, Czech Republic  
 ☎ +420 236 032 911  
 ☎ panasonic.praha@eu.panasonic.com  
 www.aircon.panasonic.cz

**Hungary / Albania / Bosnia / Bulgaria / Croatia / Kosovo / Montenegro / Romania / Serbia / Slovenia**

**Panasonic Heating & Cooling Solutions**

Alíz utca 3. - Office Garden III, 1117 Budapest,  
 Hungary  
 ☎ +36 1 700 89 65  
 ☎ panasonicaquarea@eu.panasonic.com  
 www.aircon.panasonic.eu

**United Kingdom**

**Panasonic Heating & Ventilation Air-Conditioning UK Ltd.**

Building 3, Albany Place, Hydeway, Welwyn Garden City, AL7 3BT, United Kingdom  
 ☎ +44 1707 378 670  
 ☎ sales.PHVACUK@eu.panasonic.com  
**www.aircon.panasonic.co.uk**



Do not add or replace refrigerant other than the specified type. Manufacturer is not responsible for the damage and deterioration in safety due to usage of the other refrigerant.  
 The outdoor units in this catalogue contains fluorinated greenhouse gases with a GWP higher than 150.

**Panasonic®**

To find out how Panasonic cares for you,  
 log on to: **www.aircon.panasonic.eu**

**Panasonic Marketing Europe GmbH**  
**Panasonic Heating & Ventilation Air-conditioning Europe**  
 Hagenauer Strasse 43, 65203 Wiesbaden, Germany